

Zero Backlash Speed Reducers

onvio





PRECISE

- True Zero Backlash
- 400% Shock Load Capacity
- Exceptional Torsional Stiffness
- Rigid Bearing Construction
- Smooth, Quiet Operation

INTELLIGENT

- Unique Cam Design
Allows for More Than
50 Standard Ratios
- Same Low Profile Design
Regardless of Ratio
- Integral Output Bearing

DYNAMIC

- Balanced Cam for Higher
Speeds
- Low Inertia
- High Safety Factor
- Input Speeds to 6000 rpm
- Great for High Reversing
Applications

PRECISE,

INTELLIGENT,

DYNAMIC

Today's servo motors continue to provide higher speeds and increased torque capacity in each frame size. Dynamic performance, backlash and torsional stiffness become ever more crucial to motion control systems.

Onvio's Dojen™ cycloidal speed reducers provide the highest precision available offering TRUE ZERO BACKLASH, high torsional stiffness and unmatched positioning accuracy.

Onvio has manufacturing locations in the United States, Mexico, Germany, and Spain. By employing world class manufacturing standards we are able to control all aspects of the manufacturing process which means we will deliver the right product on time. You can count on it.

onvio

Dojen™ Reducers

Ultimate Performance

In applications that demand the greatest positioning accuracy, highest torsional stiffness, and lowest backlash, Onvio's Dojen™, with its compact axial design, is the only choice.

Choose from the following options

Nine Frame Sizes

- Diameters from 4 inches up to 19 inches
 - Output Torques from 100 Lb-in to over 100,000 Lb-in
 - Input speeds to 8,000 RPM
-

Widest Ratio Range Available

- 49 Ratios Available
 - 9:1 up to 256:1
 - Stacking stages not required
-

Modularity

- Add Onvio's Right angle reducer for applications where axial space is crucial
 - Add a planetary stage and create ratios of 256,000:1 and beyond
 - Motor attaches easily using one of two available standard interface designs
-

Input Configurations

- Hollow bore input shaft for close mounting motor
- Straight shaft for use with a timing belt
- Thru-holes for passing wires
- Optimal integrated brushless servo motor



Zero Zero Backlash Speed Reducers Ultimate Performance Backlash

Onvio reducers are designed with cantilevered needle bearing cam followers and rollers—not with pins and bushings found in other cycloidal designs. This allows for a controlled pre-load between the cam and cam followers, assuring zero backlash. Pre-load is maintained throughout the design life of the reducer.

Every cam follower is in contact at all times, the load is equally shared. This guarantees consistently high torsional rigidity independent of load position.

With a high capacity output bearing and output flange, Onvio's cycloidal reducer can support most loads. Machine designs are simplified thus increasing reliability and reducing overall package size.

All steel construction for operation in wide range of temperatures.

One-piece dual reduction cam provides a wide range of ratios in a compact, low profile design.

Hollow bore input and clamp collar provide quick motor installation with no backlash.

Dynamically balanced counterweight for high speed input.

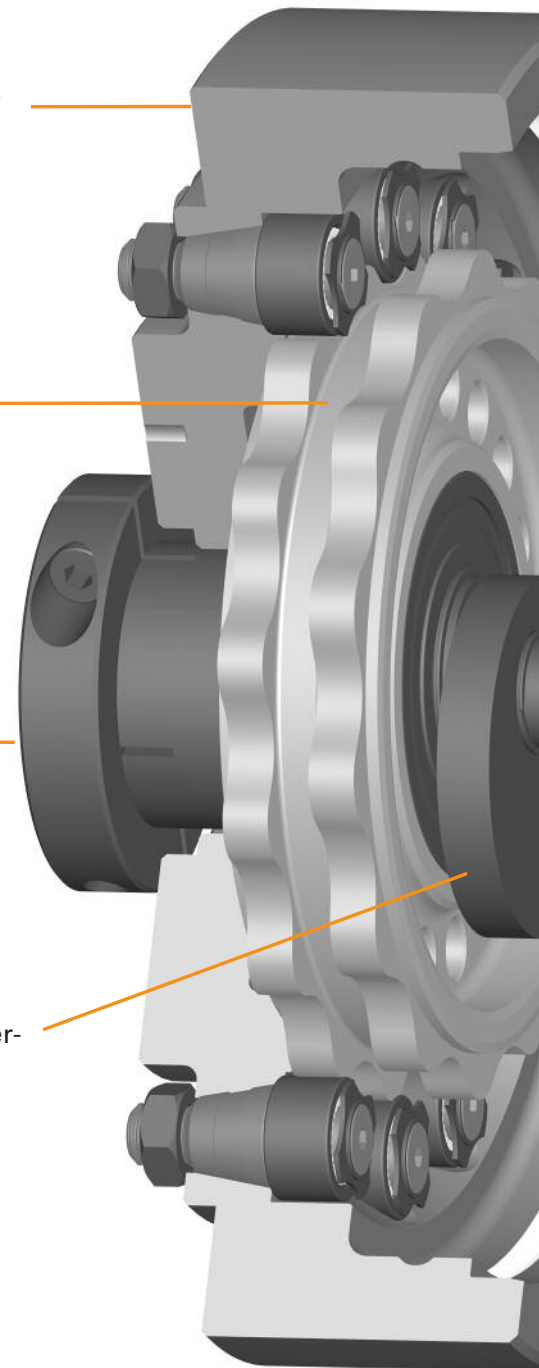

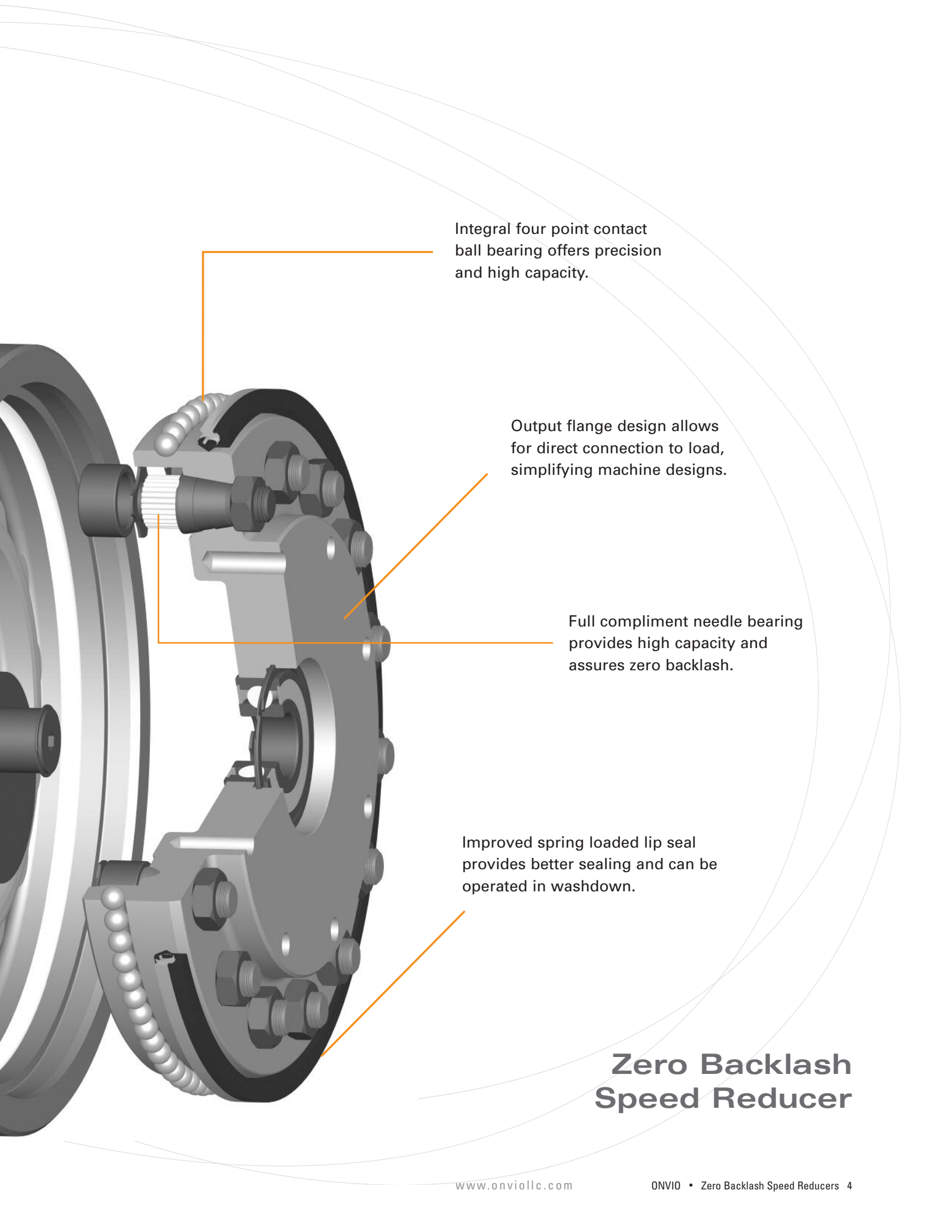

Integral four point contact ball bearing offers precision and high capacity.

Output flange design allows for direct connection to load, simplifying machine designs.

Full compliment needle bearing provides high capacity and assures zero backlash.

Improved spring loaded lip seal provides better sealing and can be operated in washdown.

Zero Backlash Speed Reducer

Pancake Series

Dimensions

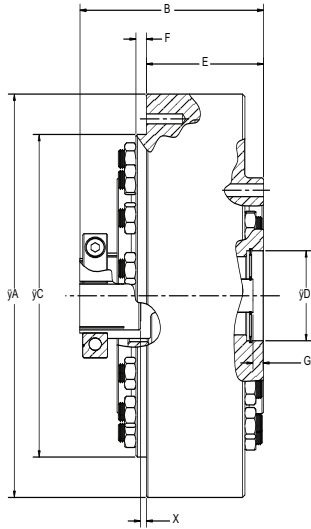

Overall Dimensions

Model No.	Diameter A		Length B		Weight	
	Inch	mm	Inch	mm	Lbs	Kg
M02	4.000	101.60	2.63	66.80	4.4	2
M03	5.250	133.35	2.94	74.68	8.8	4
M04	7.125	180.98	3.22	81.74	19	8.64
M05	8.125	206.38	3.68	93.35	28.2	12.82
M06	10.125	257.18	4.31	109.53	47.4	21.55
M08	12.250	311.15	5.25	133.35	83	37.73
M10	15.000	381.00	6.00	152.40	156	70.91
M12	19.250	488.95	11.18	283.97	287	130.45

Base (Housing) Installation

Model No.	Pilot Diameter C ¹		Pilot Depth F		Thread Size		Bolt Circle		No. of holes
	Inch	mm	Inch	mm	Inch	mm	Inch	mm	
M02	3.030	76.962	0.23	5.84	#10-32 UNF x .38 dp	M5 x .8 x 9.6 dp	3.329	84.557	12
M03	3.999	101.575	0.17	4.32	#10-32 UNF x .44 dp	M5 x .8 x 11 dp	4.438	112.725	12
M04	5.499	139.675	0.31	7.95	1/4-28 UNF x .40 dp	M6 x 1 x 10.92 dp	6.000	152.400	12
M05	6.499	165.075	0.21	5.33	1/4-28 UNF x .62 dp	M6 x 1 x 16 dp	7.125	180.975	12
M06	7.999	203.175	0.38	9.65	5/16-24 UNF x .62 dp	M8 x 1.25 x 16 dp	8.625	219.075	12
M08	9.874	250.800	0.32	8.13	3/8-24 UNF x .62 dp	M10 x 1.5 x 16 dp	10.750	273.051	12
M10	11.749	298.425	0.47	11.94	1/2-20 UNF x .93 dp	M12 1.75 x 23.6 dp	13.000	330.201	12
M12	16.749	425.425	0.58	14.73	1/2-20 UNF x 1 dp	M12 x 1.75 x 25.4 dp	18.000	457.201	12

Load Installation

Model Size	Pilot Diameter D ²		Pilot Depth G		Thread Size		Bolt Circle		No. of holes	Mount Face to Load Face Length E	
	Inch	mm	Inch	mm	Inch	mm	Inch	mm		Inch	mm
M02	1.375	34.925	0.09	2.29	#10-32 UNF x .32 dp	M5 x .8 x 8.1 dp	1.693	43.002	8	1.56	39.624
M03	1.437	36.500	0.09	2.29	1/4-28 UNF x .38 dp	M6 x 1 x 9.6 dp	2.000	50.800	8	1.75	44.450
M04	1.625	41.275	0.12	3.05	1/4-28 UNF x .5 dp	M6 x 1 x 12.7 dp	3.562	90.475	8	1.89	48.006
M05	1.812	46.025	0.15	3.81	5/16-24 UNF x .62 dp	M6 x 1 x 16 dp	4.250	107.950	8	2.36	59.944
M06	2.187	55.550	0.15	3.81	5/16-24 UNF x .62 dp	M8 x 1.25 x 16 dp	5.000	127.000	8	2.62	66.548
M08	2.812	71.425	0.15	3.81	3/8-24 UNF x .75 dp	M10 x 1.5 x 19 dp	6.375	161.925	8	3.06	77.724
M10	3.625	92.075	0.19	4.83	1/2-20 UNF x .93 dp	M12 1.75 x 23.6 dp	7.750	196.850	8	3.81	96.774
M12	7.004	177.902	0.50	12.70	5/8-16 UNF x 1.25 dp	M16 x 2 x 32 dp	10.000	254.001	8	6.00	152.400

¹Pilot diameter tolerance +.000
-.002

²Pilot diameter tolerance +.002
-.000

Note: All dimensions subject to change. Please call for specification control drawing.

Pancake Series

Performance Rating

Performance Specifications

Size	Ratio ¹	Continuous Output Torque ²		Max. Instantaneous Output Torque		Max. Input Speed RPM	Max. Output Speed ³ RPM	Torsional Stiffness		Backlash Arc-Min	Accuracy Arc-Min	Output Bearing Loads					
		Lb-In	Nm	Lb-In	Nm			Lb-In Arc-Min	Nm/Arc Min			LB	Newton	LB	Newton	Lb-In	Nm
M02	-27:1	100	11	400	45	8000	296	9.0	1.0	0	±2	560	2491	1410	6272	930	105
	-55:1	100	11	400	45	8000	145	10.0	1.1	0	±2	560	2491	1410	6272	930	105
	+100:1	100	11	400	45	8000	80	7.0	0.8	0	±2	560	2491	1410	6272	930	105
	+196:1	100	11	400	45	8000	40	29.0	3.3	0	±2	560	2491	1410	6272	930	105
M03	+25:1	500	56	2000	226	6000	240	38.0	4.3	0	±1	860	3825	2130	9474	1890	215
	-55:1	500	56	2000	226	6000	109	58.5	6.6	0	±1	860	3825	2130	9474	1890	215
	+105:1	500	56	2000	226	6000	57	75.5	8.5	0	±1	860	3825	2130	9474	1890	215
	+225:1	500	56	2000	226	6000	27	87.0	9.9	0	±1	860	3825	2130	9474	1890	215
M04	+25:1	1000	113	4000	452	5000	200	102.0	11.5	0	±1	1630	7250	4120	18326	4900	554
	-55:1	1000	113	4000	452	5000	91	131.0	14.8	0	±1	1630	7250	4120	18326	4900	554
	+105:1	1000	113	4000	452	5000	47	203.5	23.0	0	±1	1630	7250	4120	18326	4900	554
	+225:1	1000	113	4000	452	5000	22	218.0	24.5	0	±1	1630	7250	4120	18326	4900	554
M05	+25:1	1500	169	6000	678	4000	160	145.5	16.5	0	±1	1820	8095	4540	20194	6360	720
	-55:1	2000	226	8000	904	4000	73	247.0	28.0	0	±1	1820	8095	4540	20194	6360	720
	+105:1	2000	226	8000	904	4000	38	320.0	36.0	0	±1	1820	8095	4540	20194	6360	720
	+225:1	2000	226	8000	904	4000	18	436.0	49.5	0	±1	1820	8095	4540	20194	6360	720
M06	+25:1	3000	339	12000	1356	3000	120	640	73	0	±1	4020	17881	10060	44747	17600	1990
	-55:1	4000	452	16000	1808	3500	64	756	86	0	±1	4020	17881	10060	44747	17600	1990
	+105:1	4000	452	16000	1808	3500	33	902	102	0	±1	4020	17881	10060	44747	17600	1990
	+225:1	4000	452	16000	1808	3500	16	1049	119	0	±1	4020	17881	10060	44747	17600	1990
M08	+25:1	4750	537	19000	2147	3000	120	787	89	0	±1	4630	20594	11530	51285	24800	2802
	-55:1	7000	791	28000	3164	3000	55	1166	132	0	±1	4630	20594	11530	51285	24800	2802
	+105:1	7000	791	28000	3164	3000	28	1650	181	0	±1	4630	20594	11530	51285	24800	2802
	+225:1	7000	791	28000	3164	3000	13	1750	263	0	±1	4630	20594	11530	51285	24800	2802
M10	+25:1	11000	1243	28600	4972	2000	80	1150	130	0	±1	8490	37764	21100	93853	55200	6238
	-55:1	14000	1582	36400	6328	2400	44	1700	192	0	±1	8490	37764	21100	93853	55200	6238
	+105:1	14000	1582	36400	6328	2400	23	2186	247	0	±1	8490	37764	21100	93853	55200	6238
	+225:1	14000	1582	36400	6328	2400	11	3000	375	0	±1	8490	37764	21100	93853	55200	6238
M12	+25:1	25000	2825	65000	11299	1500	60	Consult Factory	0	±1	10100	44925	25200	112090	85900	9707	
	-55:1	34000	3390	78000	13559	2000	36	Consult Factory	0	±1	10100	44925	25200	112090	85900	9707	
	+105:1	34000	3842	88400	15367	2000	19	Consult Factory	0	±1	10100	44925	25200	112090	85900	9707	
	+225:1	34000	3842	88400	15367	2000	9	Consult Factory	0	±1	10100	44925	25200	112090	85900	9707	

¹ Additional ratios available. See ratio table for a complete list.

² Continuous torque based on an L10 bearing life of 1 million revolutions of the output shaft.

³ Max. output speeds are based on intermittent duty. Actual speeds will vary depending on bearing loads..

Additional Ratios Available

+10:1	+28:1	-44:1	-77:1	-143:1
+11:1	-31.5:1	+45:1	+78:1	+144:1
+12:1	-32:1	-46.6:1	-90:1	-168:1
+13:1	+32.5:1	+47.6:1	+91:1	+169:1
+14:1	+33:1	-54:1	-99:1	-195:1
+15:1	-37.5:1	+56:1	+100:1	+196:1
+16:1	+38.5:1	-64:1	-104:1	-224:1
-24:1	-39:1	+65:1	-120:1	
-27:1	+40:1	+66:1	+121:1	

Ratios: Onvio's cycloidal reducer offers the most ratios with the widest range available. The unique cam design allows all ratios to be achieved without stacking stages, so the reducer's package size never changes.

The - and + indicators that precede the reduction indicate the rotation of the output shaft relative to the direction of the input shaft.

In negative ratios, the output shaft rotates opposite the input shaft.

In positive ratios, the output shaft rotates in the same direction as the input shaft.

M-24 Series

Dimensions

Special features of the high torque M-24

- 3 times the power in the same diameter
- Full complement output bearing
- Higher ratios—up to 256:1
- Higher input speeds—up to 4500 rpm
- Greater positioning accuracy (± 330 arc seconds)
- Thru-hole capability

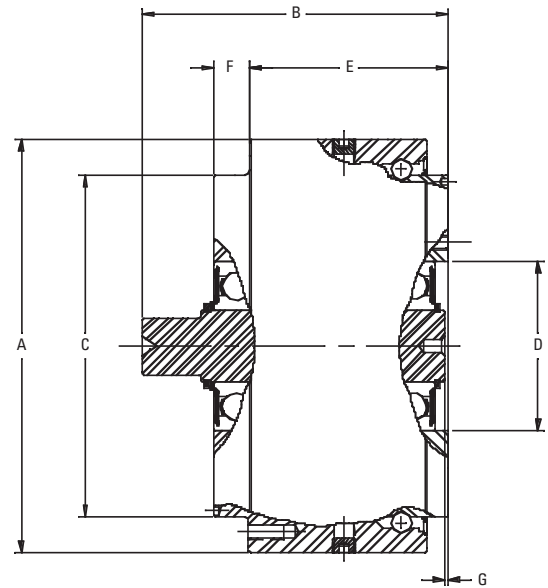

Overall Dimensions

Model No.	Diameter A		Length B		Weight	
	Inch	mm	Inch	mm	Lbs	Kg
M24	7.250	184.15	5.38	136.65	35	15.91

Base (Housing) Installation

Model No.	Pilot Diameter C ¹		Pilot Depth F		Thread Size		Bolt Circle		No. of holes
	Inch	mm	Inch	mm	Inch	mm	Inch	mm	
M24	5.999	152.37	0.88	22.35	1/4-28 UNF x .56 dp	M6 x 1.00 x 14.2 dp	6.500	165.100	12

Load Installation

Model No.	Pilot Diameter D ²		Pilot Depth G		Thread Size		Bolt Circle		No. of holes	Mount Face to Load Face Length E	
	Inch	mm	Inch	mm	Inch	mm	Inch	mm		Inch	mm
M24	2.953	75.00	0.15	3.81	1/4-28 UNF x .56 dp	M6 x 1.00 x 14.2 dp	3.625	92.07	12	3.50	88.9

¹Pilot diameter tolerance +.000
-.002

²Pilot diameter tolerance +.002
-.000

Note: All dimensions subject to change. Please call for specification control drawing.

M-24 Series

Performance Ratings

Performance Specifications

Model No.	Ratio ¹	Continuous Output Torque ²		Max. Instantaneous Output Torque		Max. Input Speed	Max. Output Speed ³	Torsional Stiffness		Backlash	Accuracy	Output Bearing Loads					
												Radial		Thrust		Bending Moment	
												Lb-In	Nm	Lb-In	Nm	Lb-In	Nm
M24	-20:1	2736	309	5448	616	4500	225	Lb-In 177.0	Nm/Arc 20.0	0	±.5	3200	14234	8000	35584	10000	1130
	-55:1	3835	433	8583	970	4500	82	230.0	26.0	0	±.5	3200	14234	8000	35584	10000	1130
	+100:1	5000	565	9480	1071	4500	45	247.0	28.0	0	±.5	3200	14234	8000	35584	10000	1130
	+225:1	3350	378	8100	915	4500	20	233.0	26.5	0	±.5	3200	14234	8000	35584	10000	1130

¹ Additional ratios available. See ratio table for a complete list.

² Continuous torque based on an L10 bearing life of 1 million revolutions of the output shaft.

³ Max. output speeds are based on intermittent duty. Actual speeds will vary depending on bearing loads.

Additional Ratios Available

+9:1	-24:1	-44:1	-77:1	-143:1
+10:1	+25:1	+45:1	+78:1	+144:1
+11:1	-27:1	-46.6:1	-80:1	-168:1
+12:1	+28:1	+47.6:1	+81:1	+169:1
+13:1	-32:1	-54:1	-90:1	-195:1
+14:1	+33:1	+56:1	+91:1	+196:1
+15:1	+38.5:1	-64:1	-104:1	-224:1
+16:1	-39:1	+65:1	-120:1	-255:1
+21:1	+40:1	+66:1	+121:1	+256:1

Ratios: Onvio's cycloidal reducer offers the most ratios with the widest range available. The unique cam design allows all ratios to be achieved without stacking stages, so the reducer's package size never changes.

The - and + indicators that precede the reduction indicate the rotation of the output shaft relative to the direction of the input shaft.

In negative ratios, the output shaft rotates opposite the input shaft.

In positive ratios, the output shaft rotates in the same direction as the input shaft.

Additional Specification

Back Driveability

Model No.	Breakaway Torque		Running Torque	
	Lb-In	Nm	Lb-In	Nm
M02	180	20	120	14
M03	750	85	600	68
M04	1800	203	1200	136
M05	3600	407	2400	271
M06	7200	814	4800	542
M24	7200	814	4800	542
M08	12600	1424	8400	949
M10	25200	2847	16800	1898
M12	61200	6915	40800	4610

Backdrivable Ratios: 10:1 to 90:1, 104:1 & 105:1

Locking Ratios*: 99:1 to 256:1

* Locking ratios are not designed as a safety stop. A brake should be used for inertial loads and in applications where gravitational loads must be held.

Back Driveability

One of the unique features of Dojen technology is its ability to be used as a speed increaser as well and as a speed reducer. This "backdriveability" is a necessary feature in reduction applications that have high inertial loads.

Additional Specification

Input Torque Variables

Model	Input Inertia		Collet Inertia		Tare Torque		% Net Efficiency
	Lb-In-sec ²	Kg Cm ²	Lb-In-sec ²	Kg Cm ²	Lb-In	Nm	
M02	0.00018	0.2034	0.00013	0.1469	1.5	0.2	70
M03	0.00035	0.3854	0.00023	0.2599	3	0.3	75
M04	0.00108	1.2202	0.00056	0.6327	5.5	0.6	80
M05	0.0032	3.6155	0.0011	1.2428	8	0.9	80
M06	0.0062	7.0051	0.002	2.2597	12.5	1.4	80
M24	0.006	6.779	N/A	N/A	10	1.1	90
M08	0.018	20.3373	0.0043	4.8584	18	2.0	85
M10	0.037	41.8045	0.0043	4.8584	27	3.1	85
M12	0.02	22.5970	N/A	N/A	40	4.5	85

Tare Torque: Tare torque is the friction from the preload, bearings, grease, etc. The tare torque is the amount of torque it takes to continuously operate the reducer at 1,500 RPM input speed.

Motor Bearing Dynamic Radial Loads

Onvio's unique collet input shaft gives designers the shortest axial package available. The motor shaft is close coupled with the reducer input shaft. When this design is used, the motor bearing is very close to the reducer's input shaft. We remove the rear support bearing in order to avoid too many bearings in a row. Under load, the motor bearing will see a radial load from the reducer input. The following chart provides the radial load at rated output torque. The load varies with the amount of output torque and the relationship is linear.

Dynamic Radial Loads for Standard Ratios

Ratio	M02		M03		M04		M05		M06		M24		M08		M10		M12
	Lb	N	Lb	N	Lb	N	Lb	N	Lb	N	Lb	N	Lb	N	Lb	N	
25	53	236	172	765	218	970	351	1561	565	2513	N/A	N/A	709	3154	1140	5071	Consult
55	30	133	85	378	109	485	171	761	272	1210	N/A	N/A	339	1508	540	2402	Onvio
105	20	89	50	222	65	289	89	396	156	694	N/A	N/A	192	854	302	1343	
225	14	62	30	133	39	173	57	254	88	391	N/A	N/A	106	471	162	721	

If the motor bearing can not support the reflected radial load, Onvio offers an added support bearing and male input shaft. Please refer to page 10 for standard dimensions.

Contact Onvio application engineering for additional ratios or for assistance.

Efficiency, Lubrication, and Temperatures

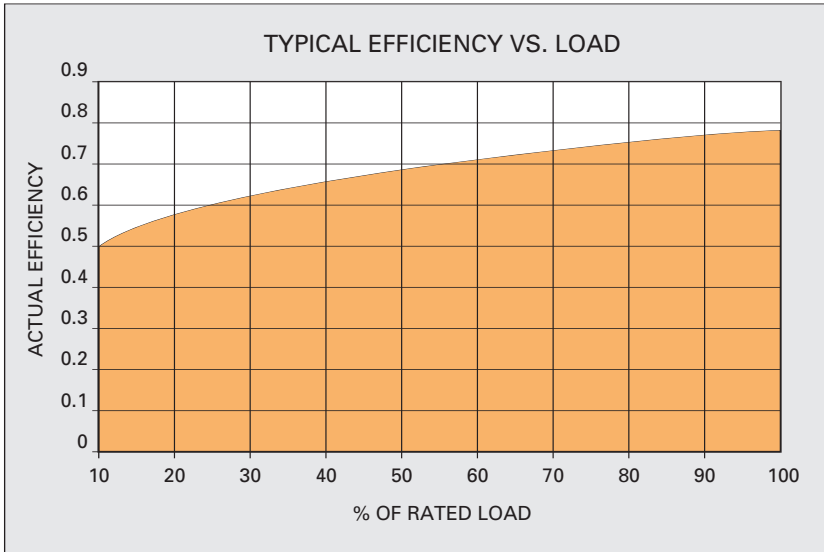

Grease Chart

	Standard Grease	Extreme Cold Temps	Extreme High Temps
Model 02	Shell Alvania II	Amoco Supermil ¹	Magnalube G1/3 ¹
Model 03	Shell Alvania EP1	Amoco Supermil ¹	Magnalube G1/3 ¹
Model 04	Shell Alvania EP1	Amoco Supermil ¹	Magnalube G1/3 ¹
Model 05	Shell Alvania EP1	Amoco Supermil ¹	Magnalube G1/3 ¹
Model 06	Shell Alvania EP2	Amoco Supermil ¹	Magnalube G1/3 ¹
Model 24	Shell Alvania EP2	Amoco Supermil ¹	Magnalube G1/3 ¹
Model 08	Shell Alvania EP2	Amoco Supermil ¹	Magnalube G1/3 ¹
Model 10	Shell Alvania EP2	Amoco Supermil ¹	Magnalube G1/3 ¹
Model 12	Shell Alvania EP2	Amoco Supermil ¹	Magnalube G1/3 ¹

¹ May require derating the reducer. Contact our application department for details.

Onvio also offers specialty lubrication for use in semiconductor applications, food processing, etc.

Contact our application department for details.

Lubrication

The Dojen is grease lubricated and sealed for life. However, in some high cycle applications or in environments that can prematurely cause lubricant to breakdown, we recommend purging old grease with fresh new grease. The reducer is equipped with grease ports on the outer diameter. Contact Onvio customer service for lubrication procedures and available equipment.

Standard Operating Temperatures

For normal, steady-state operation: 32°F to 150°F

Requires heatsinking/cooling: 150°F to 212°F

Input Shafts

Collet Input Shaft

Features

- Perfect for direct mounting in close quarters to a servo motor.
- No keyways, no backlash.
- Specify motor shaft diameter when ordering.
- Motor sleeves provided for any motor shaft diameter smaller than the maximum shaft diameter.
- Eliminates costly couplings.

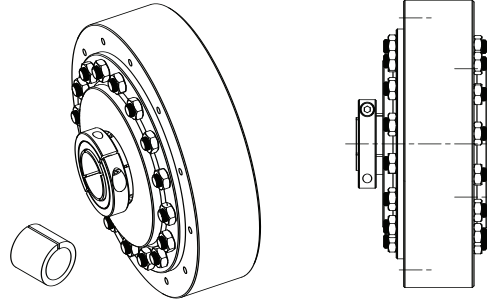

Collet Input (For direct coupling of motor shaft)

Model No.	Maximum Shaft Dimensions				Motor Sleeve Dimensions ¹			
	Shaft Diameter		Bore length		Minimum Diameter		Length	
	Inch	Metric	Inch	Metric	Inch	Metric	Inch	Metric
M02	0.551	14 mm	0.77	19.6 mm	0.250	6 mm	0.77	19.6 mm
M03	0.750	19 mm	0.90	22.9 mm	0.250	6 mm	0.90	22.9 mm
M04	1.00	24 mm	1.00	25.4 mm	0.250	6 mm	1.00	25.4 mm
M05	1.375	35 mm	1.32	33.5 mm	0.375	10 mm	1.32	33.5 mm
M06	1.375	35 mm	1.34	34 mm	0.375	10 mm	1.34	34 mm
M24	1.125	28.5 mm	.90	22.9 mm	Consult Factory			
M08	1.625	41.33 mm	1.38	35 mm	0.500	12 mm	1.38	35 mm
M10	1.625	41.33 mm	1.62	41.1 mm	0.500	12 mm	1.62	41.1 mm
M12	Consult Factory							

Straight Input Shaft

Features

- Has fully supported input shaft.
- Removes radial load from motor bearings.
- Ideal for shaft-to-shaft couplings, pulleys, gears, etc.
- Allows reducer to be used as a speed increaser in specified ratios.
- Both metric and inch sizes.
- Thru-holes available for routing wires, etc.

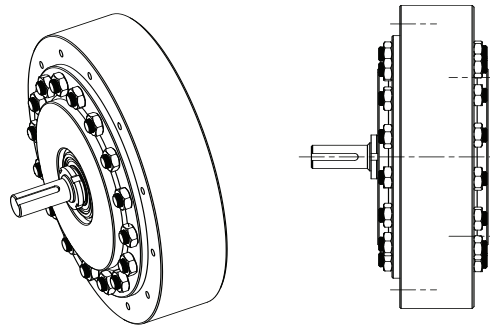

Straight Shaft Input

Model No.	Shaft Diameter		Shaft Length		Keyway		Keyway Length	
	Inch	Metric	Inch	Metric	Inch	Metric	Inch	Metric
M02	0.500	12 mm	0.50	14 mm	.125	5 mm	0.38	12 mm
M03	0.500	12 mm	1.00	25 mm	.125	5 mm	0.75	20 mm
M04	0.562	15 mm	1.25	32 mm	.125	5 mm	1.00	25 mm
M05	0.625	18 mm	1.50	35 mm	.187	6 mm	1.25	28 mm
M06	0.875	22 mm	1.75	40 mm	.187	6 mm	1.50	32 mm
M24	1.000	24 mm	1.00	24 mm	.250	8 mm	0.75	20 mm
M08	1.250	30 mm	2.50	60 mm	.250	10 mm	2.25	50 mm
M10	1.375	35 mm	3.00	80 mm	.312	12 mm	2.25	50 mm
M12	2.250	60 mm	3.50	90 mm	.500	18 mm	3.00	80 mm

Output Shafts

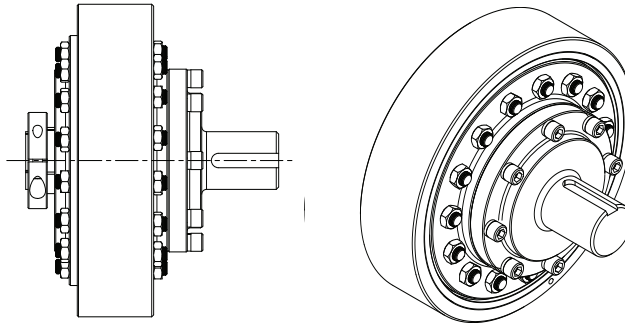

Output Shafts

Model No.	Shaft Diameter		Shaft Length		Keyway		Keyway Length	
	Inch	Metric	Inch	Metric	Inch	Metric	Inch	Metric
M02	0.625	16 mm	1.250	30 mm	.187	5 x 5 mm	1.000	24 mm
M03	0.875	22 mm	1.375	35 mm	.250	6 x 6 mm	1.125	30 mm
M04	1.250	32 mm	2.375	60 mm	.312	10 x 8 mm	2.000	55 mm
M05	1.500	40 mm	2.750	70 mm	.375	12 x 8 mm	2.375	65 mm
M06	2.000	50 mm	3.375	85 mm	.500	14 x 9 mm	2.875	80 mm
M24	2.000	50 mm	3.375	85 mm	.500	14 x 9 mm	2.875	80 mm
M08	2.375	60 mm	4.000	100 mm	.625	18 x 11 mm	3.500	90 mm
M10	Consult Factory							
M12								

Features

- Bolts directly to output face.
- Ideal for shaft-to-shaft couplings, pulleys, gears, etc.
- Available in aluminum or steel.
- Nickel plating available for wash-down compatibility.
- Both metric and inch sizes.
- Thru-holes available for routing wires, etc.

Additional Options

- Face mounted pulleys
- Large diameter thru-holes for passing wires, coolant lines, etc.
- Full complement output bearing that can handle even higher loads
- Eccentric pilot for installation and preload of rack and pinion drives
- Nickel plated finish for use in high corrosive and vacuum environments
- Custom input and output shafts
- Stacked reducers for ratios over 50,000:1

Motor Interfaces

Onvio offers three standard types of servo flanges that can be machined for use with almost any servo or stepper motor.

They include square flanges, round flanges, and foot mounts. They can be made of either steel or aluminum.

These flanges are used to interface our speed reducer to various brands of motors. Here's a partial list of brands.

Allen Bradley	Lenze
Baldor	Mavilor
Control Technique	MCG
Danaher	Moog
Electrocraft	Oriental Motor
Emerson	Pacific Scientific
Fanuc	Parvex
Global Servos	PMI Motion Technologies
Giddings & Lewis	Reliance Electric
IMS	Rockwell Automation
Indramat	Siemens
Industrial Drive	Yaskawa
Infranor	
Kollmorgen	

One of our applications engineers will be pleased to provide you with the proper CAD drawing— by mail, fax, CD, or over the internet.

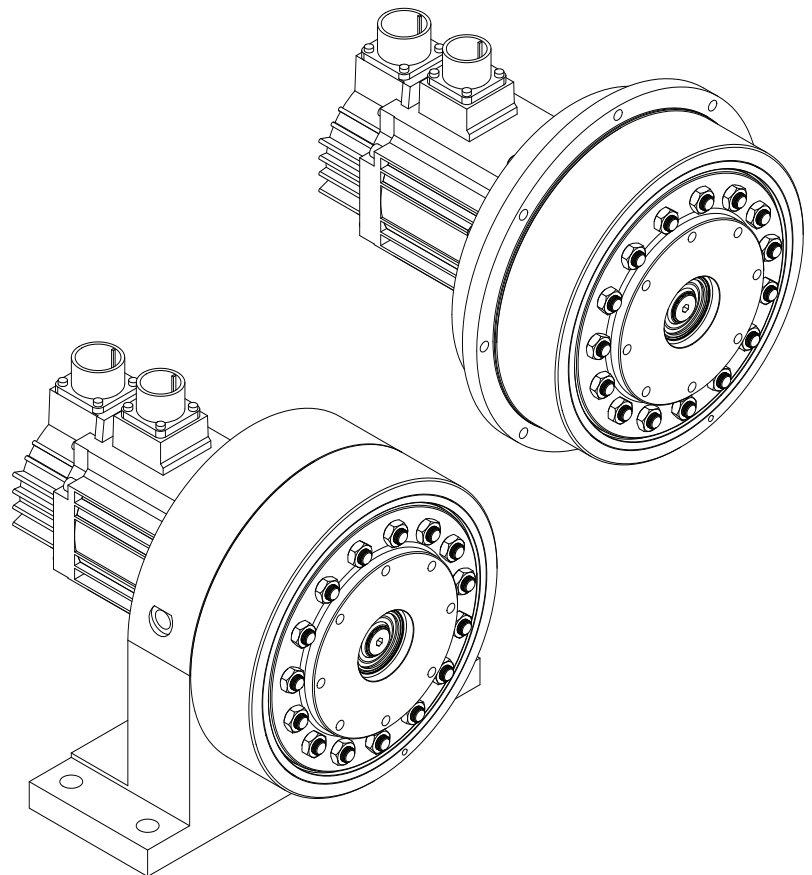
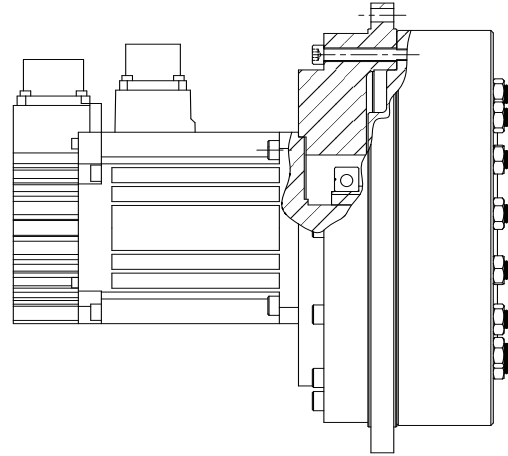

Round Face mount Flange

Model	Diameter A		Pilot Diameter B		Mount Holes C		Bolt Circle D		Pilot Thickness E		Flange Thickness F		Length G		Servo Mount			
	inch	mm	inch	mm	inch	mm	inch	mm	inch	mm	inch	mm	inch	mm	H	I	J	
M02	4.75	120.7	4.062	103.18	#10-32	M5	4.375	111.13	0.06	1.6	.35	9.0	1.973	50.1	Motor Dependent			
M03	6.00	152.4	5.374	136.50	#10-32	M5	5.750	146.05	0.06	1.6	.39	10.0	2.203	56.0				
M04	8.00	203.2	7.187	182.55	1/4-20	M6	7.625	193.67	0.06	1.6	.43	11.0	2.383	60.5				
M05	9.25	235.0	8.187	207.95	5/16-18	M8	8.750	222.25	0.06	1.6	.47	12.0	2.893	73.5				
M06	11.50	292.1	10.187	258.75	3/8-16	M10	10.750	266.70	0.13	3.2	.47	12.0	3.220	81.8				
M24	8.50	215.9	7.312	185.73	3/8-16	M10	8.000	203.20	0.13	3.2	.43	11.0	4.060	103.1				

M08

M10

M12

Consult Onvio Application Engineering

Foot Mount

Model	Width A		Diameter B		Thru Hole C		Hole Centerline D		Center Line E		Base Thickness F		Bolt Centerline G		Foot Mount Length H		Foot Mount Length I		Servo Mount			
	inch	mm	inch	mm	inch	mm	inch	mm	inch	mm	inch	mm	inch	mm	inch	mm	inch	mm	H	I	J	
M02	4.88	123.8	4.00	101.6	0.31	7.9	4.375	111.13	2.500	63.50	0.38	9.5	0.750	19.05	1.38	34.9	2.94	74.6	Motor Dependent			
M03	6.50	165.1	5.25	133.4	0.31	7.9	6.000	152.40	3.250	82.55	0.50	12.7	1.000	25.40	1.44	36.5	3.19	81.0				
M04	10.00	254.0	7.13	181.0	0.41	10.4	8.750	222.25	4.500	114.30	0.63	15.9	1.000	25.40	1.63	41.3	3.52	89.4				
M05	11.00	279.4	8.13	206.4	0.53	13.5	9.750	247.65	5.000	127.00	1.00	25.4	1.375	34.93	1.81	46.0	4.17	105.9				
M06	13.50	342.9	10.13	257.2	0.66	16.8	12.000	304.80	6.000	152.40	1.00	25.4	1.875	47.63	2.19	55.5	4.81	122.2				
M24	10.00	254.0	7.25	184.2	0.66	16.8	9.000	228.60	5.000	127.00	1.00	25.4	1.875	47.63	2.50	63.5	6.00	152.4				

M08

M10

M12

Consult Onvio Application Engineering

Install

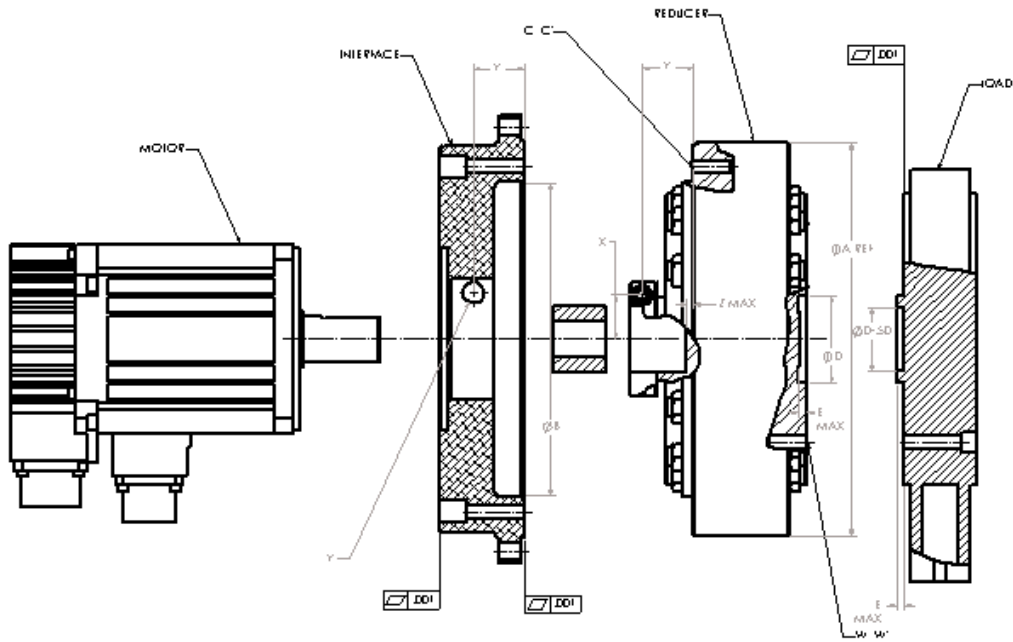

Model Number

	M02	m03	m04	m05	m24	m06	m08	m10	m12
A Reducer Diameter-in.	4.000	5.250	7.125	8.125	7.250	10.125	12.250	15.000	19.250
B Pilot Diameter-in.	3.031-3.033	4.000-4.002	5.500-5.502	6.500-6.502	6.000-6.002	8.001-8.002	9.875-9.877	11.750-11.752	16.750-16.752
C Input Side Thread/ Bolt Circle (UNF)/in.	10-32 3.329	10-32 4.438	1/4-28 6.000	5/16-24 7.125	1/4-28 6.500	5/16-24 8.625	3/8-24 10.750	1/2-20 13.000	1/2-20 18.00
C' Input Side Bolt Torque-in.-lbs.	45	45	115	115	115	320	435	1260	1260
D Output Shaft Pilot Diameter-in.	1.375-1.376	1.437-1.438	1.625-1.625	1.812-1.814	2.953-2.955	2.187-2.189	2.812-2.814	3.625-3.627	7.001-7.004
E Output Shaft Pilot Depth-in.	0.09	0.09	0.12	0.15	0.15	0.15	0.15	0.19	0.19
W Output Side Thread/ Bolt Circle (UNF)/in.	10-32 1.693	1/4-28 2.000	1/4-28 3.5462	5/16-24 4.250	1/4-28 3.625	5/16-24 5.000	3/8-24 6.375	1/2-20 7.750	5/8-18 10.00
W' Output Side Bolt Torque-in.-lbs.	45	115	115	320	115	320	435	1260	1580
X Collet Centerline Radius-in.	0.53	0.62	0.83	0.97	.83	1.06	1.19	1.19	1.45
Y Collet Tightening Hole Location-in.	0.71	0.91	1.03	1.06	1.03	1.28	1.65	1.76	3.69
Y' Collet Allen Wrench Size	3/16	3/16	3/16	3/16	3/16	1/4	1/4	1/4	1/4
Y" Collet Allen Bolt Torque-in.-lbs.	185	185	185	185	185	435	435	435	435
Z Max Motor Shaft Depth in.	0.338	0.320	0.390	0.190	1.135	0.420	0.690	0.640	1.060

Preparation

1. Dowel pinning the load to the Onvio reducer and the mounting structure to the reducer is highly recommended to reduce the hysteresis lost motion. Contact Onvio engineering for recommendations.
2. Concentricity between pilots should be within .002" TIR.
3. Flatness between mating components should be within .0005 TIR, and be free of burrs.
4. Orientation of grease ports should be considered to allow for ease of relubrication.

Installation

Note: Use Loctite on all hardware.

1. Insert allen wrench into the collet collar before sliding the motor shaft into the input shaft of the reducer. This will cause proper positioning of the collar for later tightening.
2. Tighten flange bolts of the motor to the flange and to the reducer before tightening collar. Use a crossing pattern when tightening all bolts to minimize axial load on the input shaft.
3. Tighten collar according to recommended torque specs above.
4. The load coupling can be trued up, match machined, and pinned with the output shaft to minimize position error.

Warning: Never loosen the stud nuts of a Onvio reducer. They are factory precision set. Attempting to adjust these nuts in the field will void the warranty.

Application Work Sheet

Fax to Onvio Application Engineering at 603-685-0405 or email to contact@onviollc

Name: _____

Company: _____

Address: _____

State/Province: _____ Zip Code: _____

Country: _____

Telephone: _____ Cell Phone: _____

Fax: _____

Email: _____

Please complete the following information so that our application department can better help you select the proper size Dojen speed reducer.

LOAD DATA

Load Inertia _____ lb-in-sec²

Gravitational load _____ lb-in

Friction load _____ lb-in

or

Peak Torque _____ lb-in

RMS Torque _____ lb-in

DESIRED LIFE _____ hours

BEARING LOAD DATA

Radial Load _____ lb

Thrust Load _____ lb

Moment Load _____ lb-in

VELOCITY PROFILE

Acceleration Time _____ seconds

Deceleration Time _____ seconds

Total time of index _____ seconds

Dwell (Rest) time _____ seconds

Index Angle _____ degrees

Desired Ratio _____

MOTOR MOUNTING (check one)

Direct — close coupled

Shaft to shaft coupling

Timing belt

Chain/sprocket

Other _____

Motor make & model _____

OUTPUT MOUNTING (check one)

Direct to Dojen flange

Shaft to shaft coupling

Timing belt

Chain/sprocket

Other _____

DRAWING OF APPLICATION

MY NEED IS (check one)

Urgent

3-6 month

6-12 month

Future

FOLLOW UP

(Check all that apply)

Have Salesman call

Send CAD files

Send Catalogs

Send Quotation

Conversions

Torque	1Nm = 8.85 Lb In
Stiffness	1Nm/arc min = 8.85 Lb In/arc min
Inertia	1Kgcm ² = 8.85 x 10 ⁴ Lb In sec ²
Weight	1Kg = 2.2 Lbs
Force (Bearing Loads)	1 Newton = .2248 Lbs
Dimensional	1mm = .03937 inches

Easy to Order



Onvio's unique interface design offers an oversized pilot and slotted holes. The motor bearing is free of side load, resulting in longer life and better performance.

Simplified ordering and shortened delivery time because Onvio offers standard flanges for almost any motor. Match the motor mounting dimensions with the proper flange and insert the corresponding letter into the catalog number when ordering.

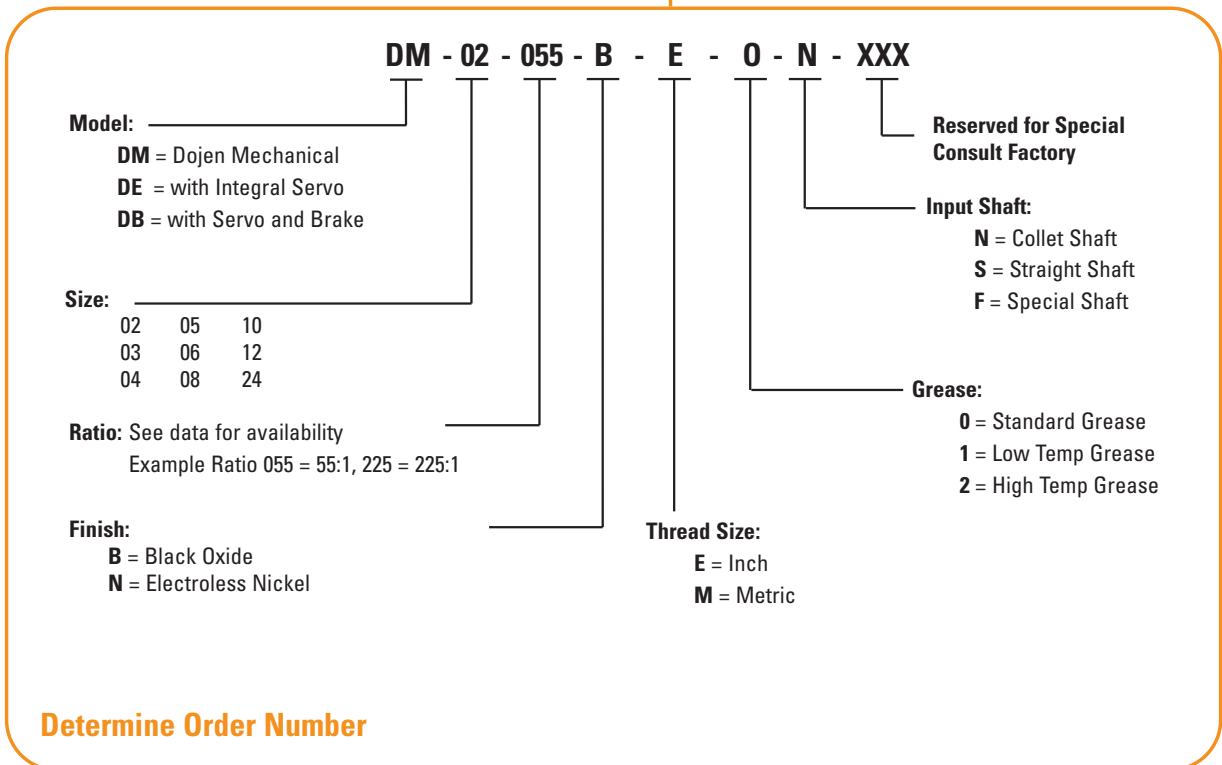

Additional Reducer Products



Planetary



Right Angle



Power Pulley



Timing Pulleys

Planetary

Onvio's revolutionary, modular approach to gearbox design has resulted in three unique families of products that offer the right performance and value for any application. The modular concept allows Onvio to provide complete OEM solutions quickly and economically.

Right Angle

In keeping with Onvio's modular concept, the right angle module is a self contained, helical bevel stage that can bolt directly on to all of Onvio's AP series products. This module provides ratios of 1:1, 3:1 and 5:1 as a standalone gearbox or attaches to our AP gearbox for ratios of 100:1.

Power Roller

Onvio's new power roller incorporates a servo motor or an induction motor to match any precision requirement. Our modular designs can be supplied in widths from .5 meters up to more than 1 meter. Onvio's power roller provides torques of more than 30 Nm with linear speeds of up to 3.1 meters/second.

Power Pulley

Onvio has combined the transmission strength of a speed reducer and the compact size of a pulley in our revolutionary gearbox in a pulley. Some of the advantages include 30% lower system cost due to fewer components, as well as higher reliability and better dynamic response.



Power Roller

Timing Pulleys

Onvio manufactures a complete line of timing pulleys for use in linear applications. Pulleys are made of aluminum, steel or stainless steel and can be supplied as complete pulley assemblies, finished pulleys or bar stock.

For questions on any of these products, contact Onvio at 1-866-685-0404 or by email at contact@onviollc.com.





www.onviolc.com

**USA
CORPORATE HEADQUARTERS**

Onvio LLC
20 Northwestern Drive
Salem, NH 03079
Tel. +1 (603) 685-0404
Tel. +1 (866) 685-0404
Fax +1 (603) 685-0405
email: contact@onviolc.com

GERMANY

Onvio GmbH
Werner von Siemens Strasse 2
64319 Pfungstadt
Tel. +49 (0) 6157 9727-111
Fax +49 (0) 6157 9727-273
email: info@onviolc.de

SPAIN

Onvio S.L.
Av. President John F. Kennedy, 20-A
E-08320 el Masnou
Barcelona
Tel. +34 (93) 540 72 54
Fax +34 (93) 540 72 97
email: onviolc@onviolc.com